

FAST & SIMPLE –
SLIP TUBES FOR EASY SOLUTION
TO LENGTH ADJUSTMENT



Original Jacob modular tubing systems are used worldwide throughout the industry for bulk goods, dust extraction and clean air handling. The main customers belong to the food and

feed industry (coffee, cocoa, chocolate, sugar, grain processing, tobacco), the chemical, pharmaceutical and plastic industry, the automotive manufacturing and the paper industry.

Maximize your benefits with Original Jacob Components

- Quick order turnaround from stock
- The modular design minimizes assembly and dismantling time
- Complete service with individual technical consulting to optimize your application.
- Top characteristics in tightness and shock explosion certified up to 3 bar.
- Top quality of the market leader.
- Special requirements available on request.
- Worldwide presence of the JACOB GROUP.

You have a choice – Slip Tube Options

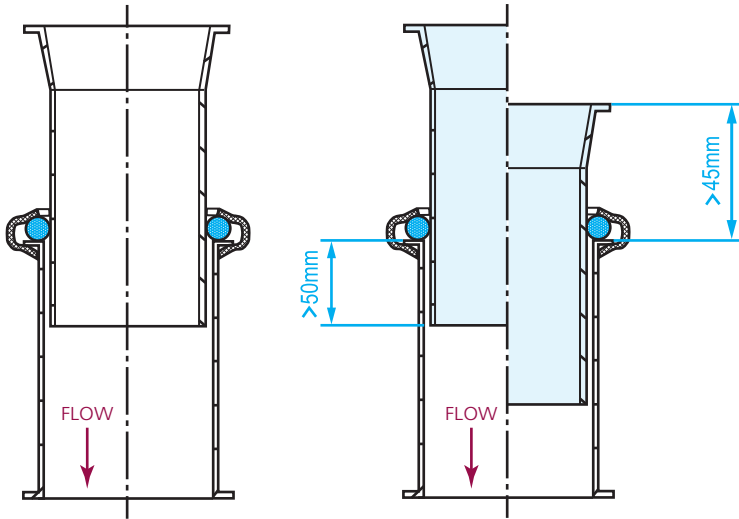

Connection of tubes 1 – 3mm wal thickness

Slip Tubes, 1 – 3mm wall thickness

- For compensating length differences
- Connection by bolted pull ring or Quick Connect® pull ring and ring seal
- Not shock explosion proof
- Admissible differential pressure 100 mbar/1.45psi/40" w.c.

1 – 2mm wall thickness

- 1000mm (39"), 500mm (20") and 200mm (8") lengths
- Diameter 80mm up to 400mm (3" – 16")
- Carbon steel powder coated, galvanized, stainless steel

3mm wall thickness

- 500mm (20") length
- Diameter 150mm (6"), 175mm (7"), 200mm (8"), 250mm (10") and 300mm (12").
- Carbon steel powder coated



Quick Connect® pull-rings for slip tubes 1 – 2 mm wall thickness used with ring seals



Bolted pull-rings for slip tubes 1 – 3 mm wall thickness used with ring seals



Ring seal for assembly of slip tubes

Ring seals for assembly of slip tubes

Made of:

NBR	Temperature resistance: -4° – 248° F (-20° – 120° C)
Silicone – food grade	-76° – 482° F (-60° – 250° C)
EPDM conductive	-4° – 248° F (-20° – 120° C)
Viton	5° – 392° F (-15° – 200° C)
Blue Detectable Design	-76° – 482° F (-60° – 250° C)

JACOB TUBING L.P.

3948 Willow Lake Blvd.
 Memphis, TN 38118
 USA
 T +1 901 566 1110
 F +1 901 566 1910
 info@jacob-tubing.com
 www.jacob-tubing.com



NO. 1 IN TUBING SYSTEMS